

**Strictly Confidential: (For Internal and Restricted use only)**

**Senior School Certificate Examination**

**Compartment July 2019**

**Marking Scheme**

**PHYSICS (SUBJECT CODE 042)**

**(PAPER CODE – 55/1/1)**

**General Instructions: -**

1. You are aware that evaluation is the most important process in the actual and correct assessment of the candidates. A small mistake in evaluation may lead to serious problems which may affect the future of the candidates, education system and teaching profession. To avoid mistakes, it is requested that before starting evaluation, you must read and understand the spot evaluation guidelines carefully. **Evaluation is a 10-12 days mission for all of us. Hence, it is necessary that you put in your best efforts in this process.**
2. Evaluation is to be done as per instructions provided in the Marking Scheme. It should not be done according to one's own interpretation or any other consideration. Marking Scheme should be strictly adhered to and religiously followed. **However, while evaluating, answers which are based on latest information or knowledge and/or are innovative, they may be assessed for their correctness otherwise and marks be awarded to them.**
3. The Head-Examiner must go through the first five answer books evaluated by each evaluator on the first day, to ensure that evaluation has been carried out as per the instructions given in the Marking Scheme. The remaining answer books meant for evaluation shall be given only after ensuring that there is no significant variation in the marking of individual evaluators.
4. Evaluators will mark(  $\checkmark$  ) wherever answer is correct. For wrong answer 'X' be marked. Evaluators will not put right kind of mark while evaluating which gives an impression that answer is correct and no marks are awarded. This is most common mistake which evaluators are committing.
5. If a question has parts, please award marks on the right-hand side for each part. Marks awarded for different parts of the question should then be totaled up and written in the left-hand margin and encircled. This may be followed strictly.
6. If a question does not have any parts, marks must be awarded in the left hand margin and encircled. This may also be followed strictly
7. If a student has attempted an extra question, answer of the question deserving more marks should be retained and the other answer scored out.
8. No marks to be deducted for the cumulative effect of an error. It should be penalized only once.
9. A full scale of marks 0-70 has to be used. Please do not hesitate to award full marks if the answer deserves it.
10. Every examiner has to necessarily do evaluation work for full working hours i.e. 8 hours every day and evaluate 20 / 25 answer books per day.
11. Ensure that you do not make the following common types of errors committed by the Examiner in the past:-
  - Leaving answer or part thereof unassessed in an answer book.
  - Giving more marks for an answer than assigned to it.
  - Wrong transfer of marks from the inside pages of the answer book to the title page.
  - Wrong question wise totaling on the title page.
  - Wrong totaling of marks of the two columns on the title page.
  - Wrong grand total.
  - Marks in words and figures not tallying.
  - Wrong transfer of marks from the answer book to online award list.
  - Answers marked as correct, but marks not awarded. (Ensure that the right tick mark is correctly and clearly indicated. It should merely be a line. Same is with the X for incorrect answer.)
  - Half or a part of answer marked correct and the rest as wrong, but no marks awarded.

12. While evaluating the answer books if the answer is found to be totally incorrect, it should be marked as (X) and awarded zero (0)Marks.
13. Any unassessed portion, non-carrying over of marks to the title page, or totaling error detected by the candidate shall damage the prestige of all the personnel engaged in the evaluation work as also of the Board. Hence, in order to uphold the prestige of all concerned, it is again reiterated that the instructions be followed meticulously and judiciously.
14. The Examiners should acquaint themselves with the guidelines given in the Guidelines for spot Evaluation before starting the actual evaluation.
15. Every Examiner shall also ensure that all the answers are evaluated, marks carried over to the title page, correctly totaled and written in figures and words.
16. The Board permits candidates to obtain photocopy of the Answer Book on request in an RTI application and also separately as a part of the re-evaluation process on payment of the processing charges.

**MARKING SCHEME (COMPARTMENT) 2019**

**SET: 55/1/1**

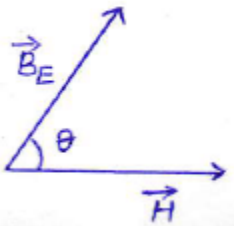
Q. NO.	VALUE POINTS/ EXPECTED ANSWERS	MARKS	TOTAL MARKS
<b>SECTION - A</b>			
1.	<p>Definition of angle of inclination: The angle which earth's magnetic field at a given place makes with the horizontal.</p> <p><u>Alternatively</u> Angle between <math>\vec{B}_E</math> and <math>\vec{H}</math></p> <p><u>Alternatively</u> Angle <math>\theta</math>, in the given figure represents the angle of inclination.</p> 	1	1
2.	<p>Most energetic radiation: Gamma rays Frequency range: <math>10^{18}</math> to <math>10^{23}</math> Hz</p> <p><b>OR</b></p> <p>(i) Ultra violet rays (ii) Frequency range: <math>10^{15}</math> to <math>10^{17}</math> Hz</p>	<p><math>\frac{1}{2}</math> <math>\frac{1}{2}</math></p> <p><math>\frac{1}{2}</math> <math>\frac{1}{2}</math></p>	1 1
3.	<p>Frequency of photon <math>\nu = E/h</math></p> $= \frac{2eV}{6.63 \times 10^{-34} \text{ Js}}$ $= \frac{2 \times 1.6 \times 10^{-19}}{6.63 \times 10^{-34}} \text{ Hz}$ $= 4.8 \times 10^{14} \text{ Hz}$ <p>[Award the last <math>\frac{1}{2}</math> mark even if the student just makes a correct substitution but does not calculate the value of <math>\nu</math>]</p> <p><b>OR</b></p> <p>(i) Yes (ii) The photo electric current is dependent on the intensity of incident radiation Because the change of intensity changes the number of photons incident per second on the photo sensitive surface.</p>	<p><math>\frac{1}{2}</math></p> <p><math>\frac{1}{2}</math> <math>\frac{1}{2}</math></p>	1 1
4.	Saturation property/ Short range nature of nuclear force	1	1
5.	<p>Frequency range of the spectrum occupied by the signal.</p> <p><u>Alternatively</u> Difference between the maximum and minimum frequencies considered essential for a given message signal</p>	1	1

Alternatively

Band width=  $v_{\max} - v_{\min}$

SECTION- B

6.

Expression for flux	1
Calculation of flux	1

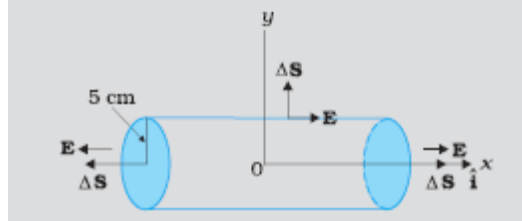

Net outward flux through the cylinder

$$\begin{aligned} \vec{E} \cdot \vec{\Delta S} &= \vec{E} \cdot \vec{\Delta S}_1 + \vec{E} \cdot \vec{\Delta S}_2 + \vec{E} \cdot \vec{\Delta S}_3 \\ &= (100 + 100)\pi r^2 + 0 \quad (\text{Here } \cos\theta = \cos 90^\circ = 0 \text{ for } \Delta S_3) \\ &= [200 \times 3.14 \times (0.05)^2] \text{ Nm}^2/\text{C} \\ &= 1.57 \text{ Nm}^2/\text{C} \end{aligned}$$

1/2

1/2

1/2

1/2

2

Alternatively:

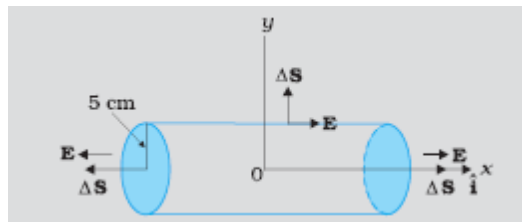

Flux through right circular surface  $\phi_1 = \vec{E} \cdot \vec{\Delta S}$

$$= 100\Delta S$$

1/2

Flux through left circular surface  $\phi_2 = \vec{E} \cdot \vec{\Delta S}$

$$= 100\Delta S$$

1/2

Flux through the curved surface  $\phi_3 = \vec{E} \cdot \vec{\Delta S}$

$$= 0$$

1/2

Net Flux  $\phi = \phi_1 + \phi_2 + \phi_3$

$$\begin{aligned} &= 200\Delta S \\ &= [200 \times 3.14 \times (0.05)^2] \text{ Nm}^2\text{C}^{-1} \\ &= 1.57 \text{ Nm}^2\text{C}^{-1} \end{aligned}$$

1/2

2

7.

Formula for Induced Emf	1
Calculation of Induced Emf	1

$$\begin{aligned} E &= \frac{1}{2} B\omega r^2 \\ &= \left[ \frac{1}{2} \times 8 \times 10^{-5} \times 4\pi \times (0.5)^2 \right] \text{ V} \end{aligned}$$

1

1/2

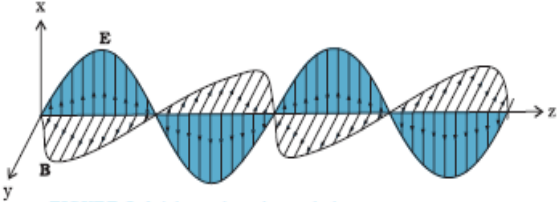
	<p style="text-align: center;"><math>= 12.56 \times 10^{-5}V</math></p> <p><b>OR</b></p> <div style="border: 1px solid black; padding: 5px; margin: 10px auto; width: fit-content;"> <p>Formula for Induced Emf      1</p> <p>Calculation of Induced Emf      1</p> </div> $\varepsilon = \frac{-d\phi}{dt}$ $= -A \frac{dB}{dt}$ $= -A \frac{dB}{dx} \times \frac{dx}{dt} = -Av \frac{dB}{dx}$ $= -[(0.1)^2 \times (-8 \times 10^{-3})]V$ $= 8 \times 10^{-5}V$	<p><math>\frac{1}{2}</math></p> <p><math>\frac{1}{2}</math></p> <p><math>\frac{1}{2}</math></p> <p><math>\frac{1}{2}</math></p>	<p>2</p> <p>2</p>
<p><b>8.</b></p> <p>(a)</p>	<div style="border: 1px solid black; padding: 5px; margin: 10px auto; width: fit-content;"> <p>(a) Graph of em wave      1</p> <p>(b) (i) Relation between <math>c</math>, <math>E_0</math> and <math>B_0</math>      <math>\frac{1}{2}</math></p> <p>(ii) Expression for speed of em wave      <math>\frac{1}{2}</math></p> </div>  <p>(b)</p> <p>(i) <math>c = \frac{E_0}{B_0}</math></p> <p>(ii) <math>c = \frac{1}{\sqrt{\epsilon_0 \mu_0}}</math></p>	<p>1</p> <p><math>\frac{1}{2}</math></p> <p><math>\frac{1}{2}</math></p>	<p>2</p>
<p><b>9.</b></p>	<div style="border: 1px solid black; padding: 5px; margin: 10px auto; width: fit-content;"> <p>Expression for wavelength in terms of the quantum number of the orbit      1</p> <p>Ratio of wavelengths in the two orbits      1</p> </div> $2\pi r_n = n \lambda_n$ $r_n = a_0 n^2$ $\therefore \lambda_n = 2\pi a_0 n$	<p><math>\frac{1}{2}</math></p> <p><math>\frac{1}{2}</math></p> <p>1</p>	<p>2</p>

$$= \frac{\lambda_1}{\lambda_2} = \frac{1}{2}$$

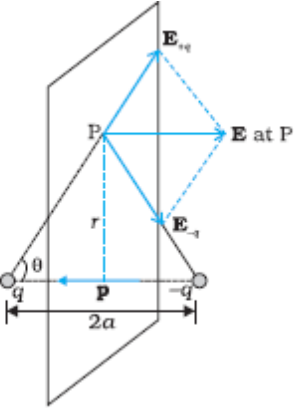
<p><b>10.</b></p>	<div style="border: 1px solid black; padding: 5px; margin-bottom: 10px;"> <table style="width: 100%; border-collapse: collapse;"> <tr> <td style="padding: 2px;">Cause of attenuation</td> <td style="text-align: right; padding: 2px;">1</td> </tr> <tr> <td style="padding: 2px;">Factors affecting the range</td> <td style="text-align: right; padding: 2px;">1</td> </tr> </table> </div> <p>Cause: absorption of waves by earth            Factors: (i) Transmitted Power            (ii) Frequency</p>	Cause of attenuation	1	Factors affecting the range	1	<p>1 1/2 1/2</p>	<p>2</p>										
Cause of attenuation	1																
Factors affecting the range	1																
<p><b>11.</b></p>	<div style="border: 1px solid black; padding: 5px; margin-bottom: 10px;"> <table style="width: 100%; border-collapse: collapse;"> <tr> <td style="padding: 2px;">Diagram</td> <td style="text-align: right; padding: 2px;">1/2</td> </tr> <tr> <td style="padding: 2px;">Electric field due to point charges</td> <td style="text-align: right; padding: 2px;">1/2</td> </tr> <tr> <td style="padding: 2px;">Net electric field</td> <td style="text-align: right; padding: 2px;">1</td> </tr> </table> </div> <div style="text-align: center; margin-bottom: 10px;">  </div> $E_{+q} = \frac{1}{4\pi\epsilon_0} \frac{q}{(r^2 + a^2)}$ $E_{-q} = \frac{1}{4\pi\epsilon_0} \frac{q}{(r^2 + a^2)}$ $E = E_{+q} \cos\theta + E_{-q} \cos\theta$ $= 2E_{+q} \cos\theta$ $= \frac{2qa}{4\pi\epsilon_0 (r^2 + a^2)^{3/2}}$ <p><b>OR</b></p> <div style="border: 1px solid black; padding: 5px; margin-bottom: 10px;"> <table style="width: 100%; border-collapse: collapse;"> <tr> <td style="padding: 2px;">Diagram</td> <td style="text-align: right; padding: 2px;">1/2</td> </tr> <tr> <td style="padding: 2px;">Expression for torque</td> <td style="text-align: right; padding: 2px;">1/2</td> </tr> <tr> <td style="padding: 2px;">Expression for P.E.</td> <td style="text-align: right; padding: 2px;">1/2</td> </tr> <tr> <td style="padding: 2px;">Minimum value of P.E.</td> <td style="text-align: right; padding: 2px;">1/2</td> </tr> </table> </div>	Diagram	1/2	Electric field due to point charges	1/2	Net electric field	1	Diagram	1/2	Expression for torque	1/2	Expression for P.E.	1/2	Minimum value of P.E.	1/2	<p>1/2  1/2  1/2  1/2</p>	<p>2</p>
Diagram	1/2																
Electric field due to point charges	1/2																
Net electric field	1																
Diagram	1/2																
Expression for torque	1/2																
Expression for P.E.	1/2																
Minimum value of P.E.	1/2																

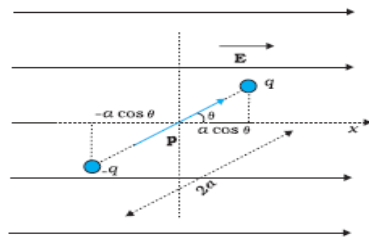

Torque  $\tau = pE \sin\theta$

$$P.E. = W = \int_{\theta_0}^{\theta} pE \sin\theta \, d\theta$$

$$= -pE (\cos\theta - \cos\theta_0)$$

$$= -pE \cos\theta \quad (\text{for } \theta_0 = \pi/2)$$

$\therefore$  Minimum value of P.E. = - p E

[Note: Award the last 1/2 mark even if the student quotes zero (0) as the minimum value of P.E. which corresponds to the choice  $\theta_0 = 0$  (or writes that this cannot be precisely specified as it depends on the choice of  $\theta_0$ )]

1/2

1/2

1/2

2

12.

- |                     |           |
|---------------------|-----------|
| (a) Effect + Reason | 1/2 + 1/2 |
| (b) Effect + Reason | 1/2 + 1/2 |

(a)  $I = \frac{V}{\sqrt{R^2 + \omega^2 L^2}}$

When  $\omega$  increases, I decreases,  $\therefore$  brightness decreases

(b)  $I = \frac{V}{\sqrt{R^2 + \frac{1}{\omega^2 C^2}}}$

When  $\omega$  increases, I increases,  $\therefore$  brightness increases

Alternatively:

(a) Brightness decreases

Reason: The impedance of L increases with an increase in angular frequency  $\omega$

(b) Brightness increases

Reason: The impedance of C decreases with an increase in angular frequency  $\omega$

1/2

1/2

1/2

1/2

1/2

1/2

1/2

1/2

2

**SECTION- C**

13.

- |   |           |
|---|-----------|
| (a) Drift Velocity and its significance | 1/2 + 1/2 |
| Relaxation time and its significance    | 1/2 + 1/2 |
| (b) Change in drift velocity            | 1         |

(a)

**Drift Velocity:** It is the average velocity with which electrons move in a conductor when an external electric field (or potential difference) is applied across the conductor.

1/2

**Significance:** The drift velocity controls the net current flowing across any cross section./ There is no net transport of charges across any area perpendicular to the applied field.

1/2

**Relaxation time:** It is the average time between successive collisions for the drifting electrons in the conductor.

1/2

**Significance:** It is a (very important) factor in determining the electrical conductivity of a conductor at different temperatures. (It is a factor which determines the drift velocity acquired by the electrons under a given applied external electric field)

1/2

(b)

$$v_d = \frac{eV}{mL} \tau$$

1/2

$$v_{d'} = \frac{eV}{m \times 5L} \tau$$

$$= \frac{v_d}{5}$$

1/2

3

**OR**

Diagram	1/2
Expression for equivalent emf and internal resistance	2 1/2

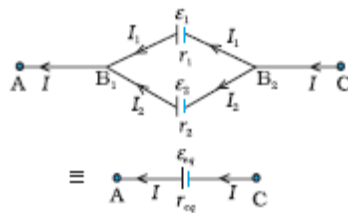

1/2

$$I = I_1 + I_2$$

$$= \left( \frac{E_1 - V}{r_1} \right) + \left( \frac{E_2 - V}{r_2} \right)$$

1/2

$$= \left( \frac{E_1}{r_1} + \frac{E_2}{r_2} \right) - V \left( \frac{1}{r_1} + \frac{1}{r_2} \right)$$

1/2

$$\text{Hence } V = \left[ \frac{E_1 r_2 + E_2 r_1}{r_1 r_2} \right] - I \left( \frac{r_1 r_2}{r_1 + r_2} \right)$$

1/2

$$\therefore E_{eff} = \frac{E_1 r_2 + E_2 r_1}{r_1 r_2}$$

1/2



	and $r_{eff} = \frac{r_1 r_2}{r_1 + r_2}$	1/2	3						
14.	<table border="1" style="width: 100%;"> <tbody> <tr> <td>(a) Correct sequence of bands</td> <td>1</td> </tr> <tr> <td>(b) Two characteristic properties</td> <td>1/2 + 1/2</td> </tr> <tr> <td>(c) Precautions (any two)</td> <td>1/2 + 1/2</td> </tr> </tbody> </table> <p>(a) Green, blue, orange, silver [Award 1/2 mark if two colours are correct in the sequence]</p> <p>(b) (i) High resistivity (ii) Low temperature coefficient of resistivity</p> <p>(c) (i) Uniformity of wire (ii) Balance point near the mid point of the wire (Also accept any other relevant precaution)</p>	(a) Correct sequence of bands	1	(b) Two characteristic properties	1/2 + 1/2	(c) Precautions (any two)	1/2 + 1/2	1 1/2 1/2 1/2 1/2	3
(a) Correct sequence of bands	1								
(b) Two characteristic properties	1/2 + 1/2								
(c) Precautions (any two)	1/2 + 1/2								
15.	<table border="1" style="width: 100%;"> <tbody> <tr> <td>(a) Reason for using shunt for conversion to ammeter</td> <td>1</td> </tr> <tr> <td>(b) Formula for shunt resistance</td> <td>1</td> </tr> <tr> <td>(c) Calculation of shunt resistance</td> <td>1</td> </tr> </tbody> </table> <p>(a) The ammeter is connected in series, in the relevant circuit branch. Hence its resistance must be (very) low so that the circuit current is not affected. A (very) low shunt resistance makes the effective resistance of galvanometer (very) low. (as required).</p> <p>(b) <math display="block">S = \frac{I_g G}{I - I_g}</math> <math display="block">= \frac{6 \times 10^{-3} \times 15}{[6 - (6 \times 10^{-3})]} \Omega</math> <math display="block">\approx 0.015 \Omega</math></p>	(a) Reason for using shunt for conversion to ammeter	1	(b) Formula for shunt resistance	1	(c) Calculation of shunt resistance	1	1 1 1/2 1/2	3
(a) Reason for using shunt for conversion to ammeter	1								
(b) Formula for shunt resistance	1								
(c) Calculation of shunt resistance	1								
16.	<table border="1" style="width: 100%;"> <tbody> <tr> <td>(a) Reason for circular motion</td> <td>1</td> </tr> <tr> <td>Expression for radius</td> <td>1</td> </tr> <tr> <td>(b) Path of the particle when <math>\Theta \neq 90^\circ</math></td> <td>1</td> </tr> </tbody> </table> <p>(a) <math display="block">\vec{F} = q(\vec{v} \times \vec{B})</math> Force <math>\vec{F}</math> on a moving charged particle in a magnetic field acts perpendicular to the velocity vector at all instants. It therefore, changes only the direction of velocity without changing its magnitude. This results in a circular motion of the particle for which the force <math>\vec{F}</math> provides the needed centripetal force <math>(= \frac{mv^2}{r})</math></p> <p style="text-align: center;">Here <math>F = qvB \sin \Theta</math>  <math>= qvB</math> (as <math>\Theta = \pi/2</math>)</p>	(a) Reason for circular motion	1	Expression for radius	1	(b) Path of the particle when $\Theta \neq 90^\circ$	1	1/2 1/2	
(a) Reason for circular motion	1								
Expression for radius	1								
(b) Path of the particle when $\Theta \neq 90^\circ$	1								

$$\therefore \frac{mv^2}{r} = qvB$$

$$\therefore r = \frac{mv}{qB}$$

(b) If  $\theta \neq 90^\circ$ , then velocity will have a component along  $\vec{B}$  also and the charged particle will move along  $\vec{B}$  with this component of velocity while describing circular motion in a plane perpendicular to  $\vec{B}$ . Its motion is, therefore, helical.

[Note: Award this 1 mark even if a student just writes that the charged particle will describe a helical path / motion.]

**OR**

Diagram	1
Working Principle	1
Two uses	$\frac{1}{2} + \frac{1}{2}$

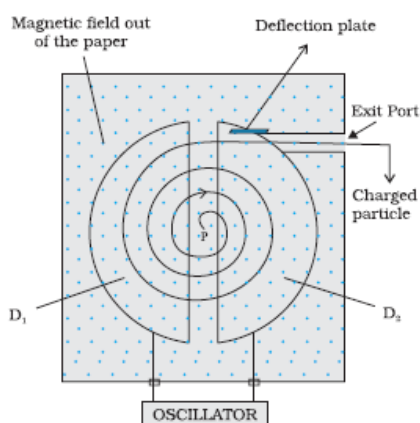

Working Principle: Cyclotron uses crossed electric and magnetic fields. Magnetic field makes the charged particle describe a circular path while electric field frequency is so adjusted as to accelerate the particle whenever it crosses the space between the dees. A relatively small electric field can then be used to accelerate particles to very high energy values.

Uses: (i) To accelerate charged particles to very high energies  
(ii) To implant ions into solids to modify their properties.  
[or any other use]

17

(a) Diagram of compound microscope	1
Working of compound microscope	1
(b) Consideration for choosing lenses for eye piece and objective	$\frac{1}{2} + \frac{1}{2}$

(a)

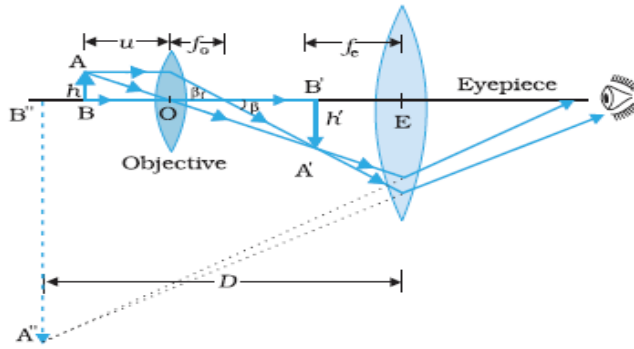

**Working:**

When object is placed just beyond the focus of objective lens, the objective forms a real and highly magnified image of the object. This image is formed at the focus of the eye piece or at a point whose distance from the eye piece is less than the focal length of the eye piece.

The eye piece then forms a (virtual) magnified image of the image formed by the objective.

(b) Both the objective and the eye piece must have short focal lengths for high magnification.

1/2

1/2

1/2 + 1/2

3

18.

Ray diagram	1
Derivation of lens formula	2

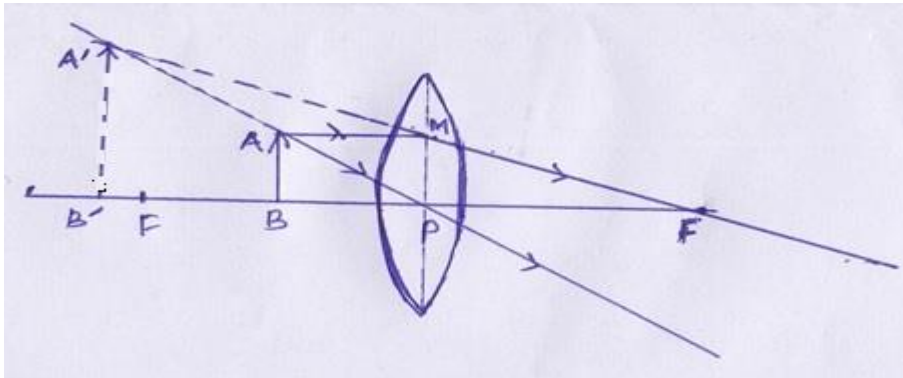

$$\Delta A'B'P \sim \Delta ABP$$

$$\frac{A'B'}{AB} = \frac{B'P}{BP} \text{ -----(i)}$$

$$\Delta A'B'F \sim \Delta MPF$$

$$\frac{A'B'}{MP} = \frac{B'F}{PF}$$

$$\text{or } \frac{A'B'}{AB} = \frac{B'F}{PF} \text{ -----(ii)}$$

From (i) and (ii)

$$\frac{B'P}{BP} = \frac{B'F}{PF}$$

1

1/2

1/2

or  $\frac{-v}{-u} = \frac{B'P+PF}{PF} = 1 + \frac{B'P}{PF}$

or  $\frac{v}{u} = 1 - \frac{v}{f}$

or  $\frac{1}{f} = \frac{1}{v} - \frac{1}{u}$

OR

Ray diagram	1
Derivation of mirror formula	2

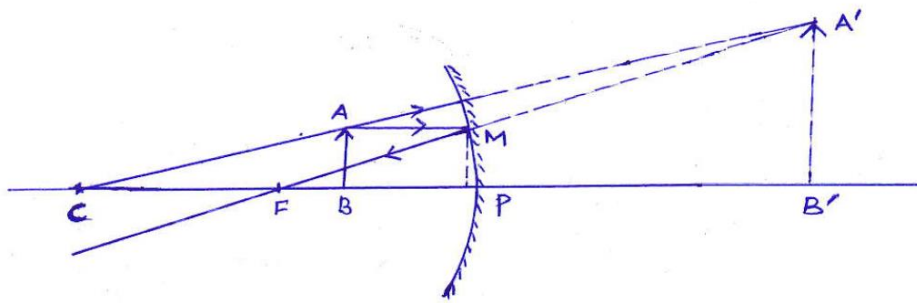

$A'B'F \sim \Delta MPF$

$\frac{A'B'}{MP} = \frac{B'F}{PF} = \frac{B'P+PF}{PF}$

or  $\frac{A'B'}{AB} = \frac{B'P+PF}{PF}$  -----(i)

$\Delta A'B'C \sim \Delta ABC$

$\frac{A'B'}{AB} = \frac{B'C}{BC} = \frac{B'P+PC}{PC-PB}$  -----(ii)

or  $\frac{B'P+PF}{PF} = \frac{B'P+PC}{PC-PB}$

or  $\frac{v-f}{-f} = \frac{v-2f}{-2f+u}$

Cross multiply and divide by uvf :

$\frac{1}{f} = \frac{1}{v} + \frac{1}{u}$

1

3

1

1/2

1/2

1

3

19.

(a) Explanation for formation of diffraction pattern	2
(b) Calculation of separation	1

(a)

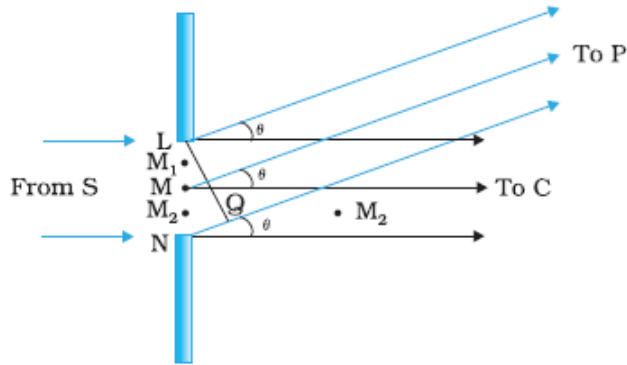

Path difference, NP-LP=NQ  
 $= a \sin \theta$   
 $\approx a \theta$

At C on the screen,  $\theta = 0^\circ$ . All path differences are zero and hence all wavelets meet in phase and produce a maxima at C.

At points P on the screen for which path difference is  $\lambda, 2\lambda, 3\lambda, \dots, n\lambda$ ; the wavelets will cancel each other in pairs and produce minima.

$\therefore a\theta = n\lambda$  ----- condition for minima  
 (n=1,2,.....)

At points P on the screen for which path difference is  $\frac{\lambda}{2}, 3\frac{\lambda}{2}, \dots$ ,  
 $(2n + 1)\frac{\lambda}{2}$ ,

The wavelets produce a maxima due to one uncancelled part of the wavefront.

$\therefore a\theta = (2n + 1)\frac{\lambda}{2}$  ----- condition for maxima  
 (n=1,2,.....)

(b) separation between 1<sup>st</sup> secondary maxima of the two wavelengths

$= \frac{3D}{2a} (\lambda_2 - \lambda_1)$

$= \frac{3 \times 1.5}{2 \times 2 \times 10^{-4}} \times 60 \times 10^{-10} \text{ m}$

$= 67.5 \times 10^{-6} \text{ m}$

$= 67.5 \mu\text{m}$

1/2

1/2

1/2

1/2

1/2

1/2

3

20.

(a) Graph	1
(b) Einstein's equation	1
Two factors which cannot be explained by wave theory	1/2 + 1/2

(a)

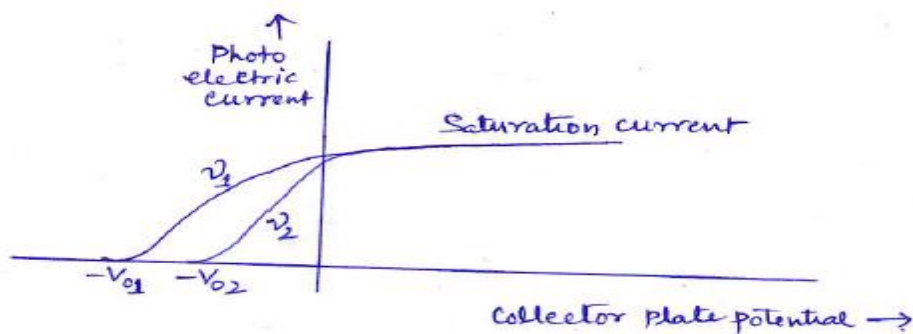

(b) Einstein's photoelectric equation

$$K_{max} = h\nu - \phi_0$$

Alternatively

$$eV_0 = h\nu - \phi_0$$

Alternatively

$$eV_0 = h\nu - h\nu_0$$

Two Factors: (i) Maximum KE of emitted photoelectrons is independent of the intensity of incident radiation

(ii) There is a threshold frequency below which photo electrons are not emitted [OR any other valid factor]

1

1

1/2

1/2

3

21.

(a) Highest energy level to which atom will be excited	1
(b) Calculation of longest Lyman wavelength	1
(c) Calculation of longest Balmer wavelength	1

(a) Maximum Energy that the excited hydrogen atom can have is

$$E = -13.6\text{eV} + 12.5\text{eV} = -1.1\text{eV}$$

$$\text{Now } E_3 = \frac{-13.6}{3^2}\text{eV} = -1.5\text{eV} \quad (< (-1.1\text{eV}))$$

$$E_4 = \frac{-13.6}{4^2}\text{eV} = -0.85\text{eV} \quad (> (-1.1\text{eV}))$$

It follows that the electron can only be excited up to the n=3 state.

(b) Longest wavelength of Lyman series:

$$\frac{1}{\lambda_L} = R \left[ \frac{1}{1^2} - \frac{1}{2^2} \right] = R \cdot \frac{3}{4}$$

$$\begin{aligned} \therefore \lambda_L &= \frac{4}{3} \times \frac{1}{R} \\ &= \frac{4}{3 \times 1.1 \times 10^7} \text{m} \cong 1218 \text{A}^0 \end{aligned}$$

Longest wavelength of Balmer series:

$$\frac{1}{\lambda_B} = R \left[ \frac{1}{2^2} - \frac{1}{3^2} \right]$$

1/2

1/2

1/2

1/2

1/2

$$\lambda_B = \left( \frac{36}{5 \times 1.1 \times 10^7} \right) m \approx 6560 \text{Å}$$

$$= \frac{5R}{36}$$

1/2

3

22.

(a) Name and Principle of the device	1/2 + 1/2
(b) Circuit diagram	1
Working	1/2
(c) I- V characteristics	1/2

(a)

Zener diode is used as a voltage regulator

It works on the principle that after the breakdown voltage  $V_Z$ , a large change in the reverse current can be produced by an almost insignificant change in the reverse bias voltage

Alternatively: The Zener Voltage remains constant, even when the current through the Zener diode varies over a wide range.

1/2

1/2

(b)

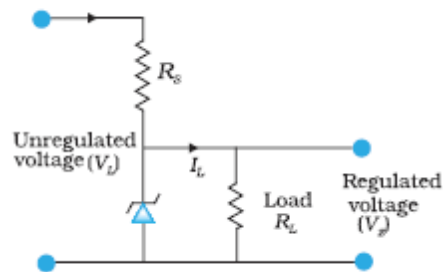

1

If the input voltage increases the current through  $R_S$  and Zener diode also increases. This increases the voltage drop across  $R_S$  without any change in the voltage across the Zener diode. If input voltage decreases, the current through  $R_S$  and Zener diode decreases. The voltage across  $R_S$  decreases without any change in voltage across the Zener diode.

1/2

(c)

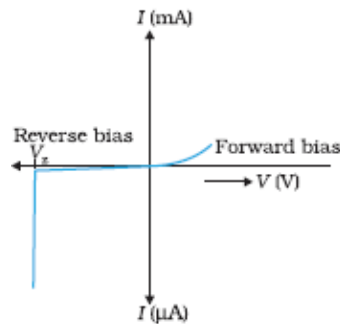

1/2

3

**OR**

(a) Truth tables of AND and NOT gates	1 + 1/2
(b) Obtaining OR gate from NAND gates	1 1/2

(a) AND gate

A	B	C
0	0	0
0	1	0
1	0	0
1	1	1

NOT gate

A	B
0	1
1	0

(b)

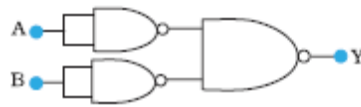

[Note: Award ½ mark if the student just writes the truth table of NAND gate without drawing any diagram]

23.

- (a) Circuit diagram for studying the characteristics of an npn transistor 1  
 (b) Finding the input resistance and current gain 1+1

(a)

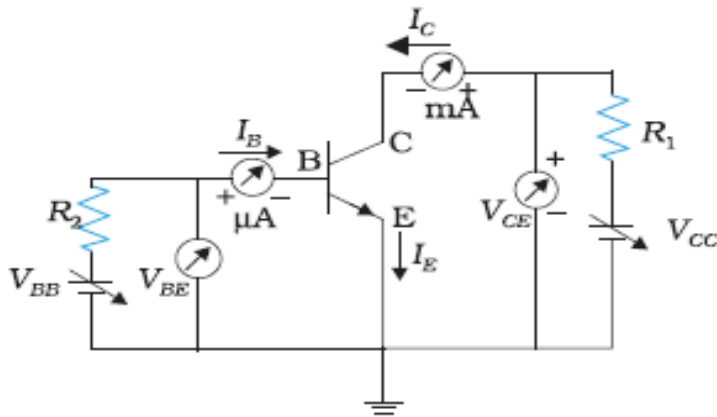

(b)



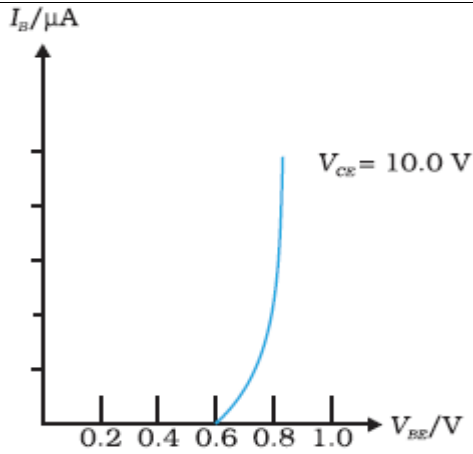

Input Resistance  $r_i = \left( \frac{\Delta V_{BE}}{\Delta I_B} \right)_{V_{CE}}$

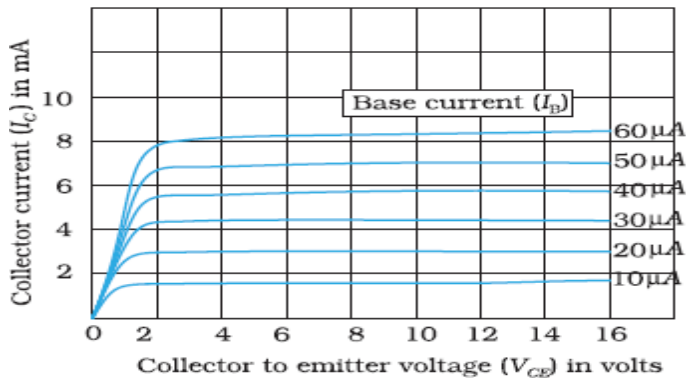

$\beta_{ac} = \left( \frac{\Delta I_C}{\Delta I_B} \right)_{V_{CE}}$

1/2

1/2

1/2

3

24.

- |   |       |
|---|-------|
| (a) Explanation of amplitude modulation | 1 1/2 |
| (b) Calculation of modulation index     | 1 1/2 |

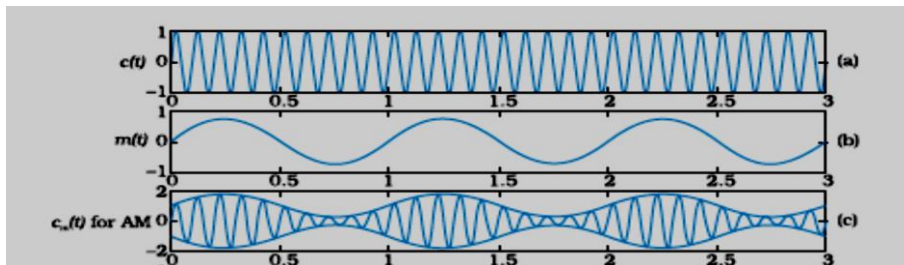

[Note: Award 1 mark here if the student just draws the diagram of the amplitude, modulated wave without drawing the 'carrier wave' and the 'message signal' diagrams]

(b)

$a_m + a_c = 20 V$

$a_c - a_m = 5 V$

1/2

1/2

1/2

$$\Rightarrow a_c = 12.5 V$$

$$a_m = 12.5 V$$

$$\begin{aligned} \text{Modulation index } \mu &= \frac{a_m}{a_c} \\ &= \frac{7.5}{12.5} = 0.6 \end{aligned}$$

1/2

1/2

1/2

3

**SECTION - D**

25.

- |   |               |
|---|---------------|
| (a) Derivation of expression for the resultant capacitance in<br>(i) parallel (ii) series | 1 1/2 + 1 1/2 |
| (b) Calculation of energy stored in the 12µf capacitor                                    | 2             |

(a) (i) Parallel

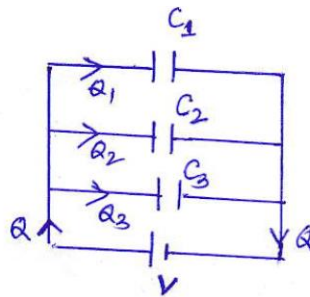

$$\begin{aligned} Q_1 &= C_1 V, \\ Q_2 &= C_2 V, \\ Q_3 &= C_3 V, \end{aligned}$$

$$\begin{aligned} \text{But } Q &= Q_1 + Q_2 + Q_3 \\ \therefore Q &= C_1 V + C_2 V + C_3 V \\ \therefore CV &= C_1 V + C_2 V + C_3 V \\ C &= C_1 + C_2 + C_3 \end{aligned}$$

(ii) Series

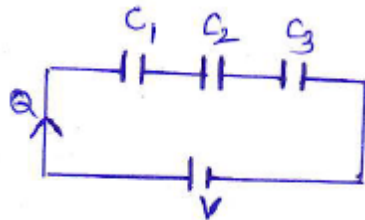

Potential difference across the plates of the three capacitors are:

$$\begin{aligned} V_1 &= \frac{Q}{C_1} \\ V_2 &= \frac{Q}{C_2} \end{aligned}$$

1/2

1/2

1/2

1/2

$$V_3 = \frac{Q}{C_3}$$

But  $V = V_1 + V_2 + V_3$

$$V = \frac{Q}{C_1} + \frac{Q}{C_2} + \frac{Q}{C_3}$$

$$\therefore \frac{Q}{C} = \frac{1}{C_1} + \frac{1}{C_2} + \frac{1}{C_3}$$

$$\therefore \frac{1}{C_{eq}} = \frac{1}{C_1} + \frac{1}{C_2} + \frac{1}{C_3}$$

1/2

(b) Potential difference across the capacitor of 4μf capacitance

$$V = \frac{Q}{C} = \frac{16\mu C}{4\mu F} = 4V$$

1/2

Potential across 12μf capacitor  
 =12 V- 4V  
 =8V

1/2

Energy stored on this capacitor

$$U = \frac{1}{2} CV^2$$

$$= \frac{1}{2} (12 \times 10^{-6}) 8^2 \text{ joule}$$

$$= 6 \times 64 \times 10^{-6} \text{ joule}$$

$$= 384 \times 10^{-6} \text{ J}$$

$$= 384 \mu\text{J}$$

1/2

1/2

5

**OR**

(a) Derivation of expression for the Electric field	
(i) inside (ii) outside	1 + 2
(b) Graphical variation of the Electric field	1
(c) Calculation of Electric flux	1

(a) (i) Inside

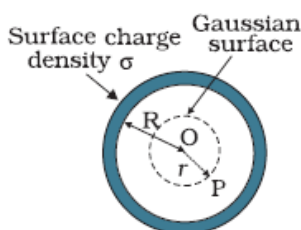

The point P is inside the spherical shell. The Gaussian surface is a sphere through P centered at 'O'

Flux through this surface=  $E \times 4\pi r^2$

However there is no charge enclosed by this Gaussian surface. Hence using Gauss's Law

$$E \times 4\pi r^2 = 0$$

$$\Rightarrow E=0$$

1/2

1/2

Outside

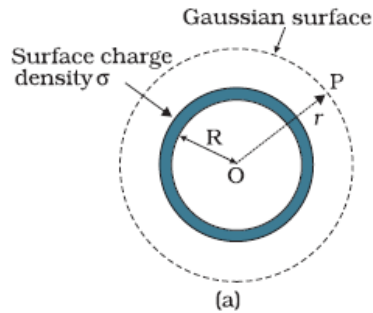

1/2

To calculate Electric Field  $\vec{E}$  at the outside point P, we take the Gaussian surface to be a sphere of radius 'r' and with center O, passing through P.

1/2

Electric Flux through the Gaussian surface

$$\phi = E \times 4\pi r^2$$

1/2

Charge enclosed by this the Gaussian surface =  $\sigma \times 4\pi R^2$

By Gauss's Law

$$E \times 4\pi r^2 = \frac{\sigma \times 4\pi R^2}{\epsilon_0} = q/\epsilon_0$$

Where q= total charge on the spherical shell.

$$\therefore E = \frac{q}{4\pi\epsilon_0 r^2}$$

$$\vec{E} = \frac{1}{4\pi\epsilon_0} \frac{q}{r^2} \hat{r}$$

1/2

(b)

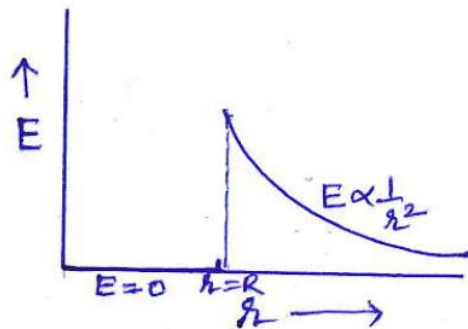

1

(c) Electric flux passing through the square sheet

$$\phi = \int \vec{E} \cdot \vec{ds}$$

1/2



resonance condition, to the rms voltage applied to the circuit.

$$Q = \frac{(V_{rms})_L [(V_{rms})_C]}{(V_{rms})_R}$$

Alternatively

Quantity factor is measure of the sharpness of the resonance in LCR circuit.

Alternatively

$$Q = \frac{1}{R} \sqrt{\frac{L}{C}}$$

**OR**

(a) Statement of Faraday's Laws	1
(b) Derivation of the expression for the emf induced across the ends of a straight conductor	2
(c) Derivation of Magnetic energy stored	2

(a) (i) Whenever there is a change in magnetic flux linked with a coil, an emf is induced in the coil, however it lasts so long as magnetic flux keeps on changing.

(ii) The magnitude of the induced emf is equal to the rate of change of magnetic flux through the circuit

Alternatively

$$\varepsilon = \frac{-d\phi}{dt}$$

(b)

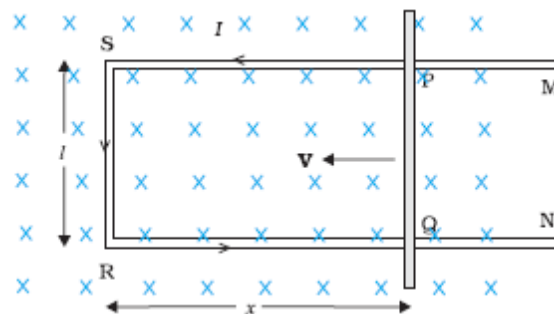

Straight conductor PQ of length 'l' is moving with velocity 'v' in uniform magnetic field B, which is perpendicular to the plane of the system.

Length RQ=x, RS=PQ=l

Instantaneous flux= (normal) field × area

The magnetic flux ( $\phi_B$ ) enclosed by the loop PQRS,

$$\therefore \phi_B = Blx$$

Since 'x' is changing with time, there is a change of magnetic flux. The rate of change of this magnetic flux determines the induced emf

1

5

1

1/2

1/2

	$\therefore e = \frac{-d\phi}{dt} = \frac{-d}{dt}(Blx)$ $= -Bl \frac{dx}{dt}$ $e = Blv$ <p>as <math>\frac{dx}{dt} = -v</math></p> <p>(c) Work done (that gets stored as the magnetic potential energy) when current 'I' flows in the solenoid.</p> $dW = (e)(Idt)$ $\therefore dW = \left(L \frac{dI}{dt}\right) \cdot (Idt)$ $\therefore dW = LI dI$ <p>Total work done <math>W = \int dW = \int LI dI</math></p> $W = \frac{1}{2} L I^2$ <p>For the solenoid, we have <math>L = \mu_0 n^2 Al</math> and <math>B = \mu_0 nI</math></p> $\therefore W = \frac{1}{2} (\mu_0 n^2 Al) \left[\frac{B}{\mu_0 n}\right]^2$ $= \frac{B^2 Al}{2\mu_0}$	<p>1/2</p> <p>1/2</p> <p>1/2</p> <p>1/2</p> <p>1/2</p> <p>1/2</p>	<p>5</p>						
<p>27.</p>	<table border="1" style="width: 100%; border-collapse: collapse;"> <tr> <td style="padding: 5px;">(a) Answer and justification</td> <td style="text-align: right; padding: 5px;">1/2 + 1/2</td> </tr> <tr> <td style="padding: 5px;">(b) Explanation of the formation of interference fringes and derivation of expression of fringe width</td> <td style="text-align: right; padding: 5px;">1 + 2</td> </tr> <tr> <td style="padding: 5px;">(c) Finding the intensity of light</td> <td style="text-align: right; padding: 5px;">1</td> </tr> </table> <p>(a) No, Because to obtain the steady interference pattern, the phase difference between the waves should remain constant with time, two independent monochromatic light sources cannot produce such light waves.</p> <p>(b) When light waves from two coherent sources, in Young's double slit experiment, superpose at a point on the screen, they produce constructive/ destructive interference, depending on the path difference between the two waves.</p>	(a) Answer and justification	1/2 + 1/2	(b) Explanation of the formation of interference fringes and derivation of expression of fringe width	1 + 2	(c) Finding the intensity of light	1	<p>1/2</p> <p>1/2</p> <p>1</p> <p>1/2</p>	
(a) Answer and justification	1/2 + 1/2								
(b) Explanation of the formation of interference fringes and derivation of expression of fringe width	1 + 2								
(c) Finding the intensity of light	1								

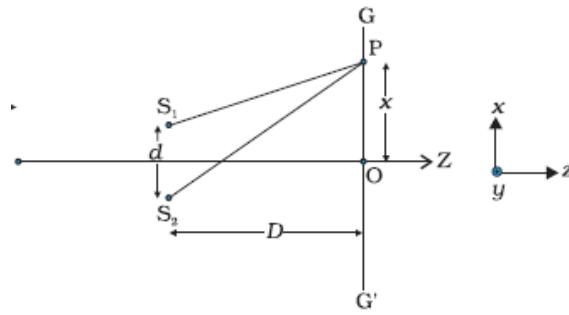

1/2

Path difference between the waves reaching at point P from two sources  $S_1$  and  $S_2$

$$S_2P - S_1P \approx \frac{xd}{D}$$

For constructive interference (i.e for  $n$ th bright fringe on the screen)

$$\frac{xd}{D} = n\lambda \quad \text{where } n = 0, \pm 1, \pm 2, \dots$$

1/2

$$\therefore x_n = \frac{n\lambda D}{d}$$

Similarly for  $(n+1)$ th bright fringe

$$x_{n+1} = \frac{(n+1)\lambda D}{d}$$

1/2

Fringe width  $\beta = x_{n+1} - x_n$

$$= \frac{\lambda D}{d}$$

[Alternatively

Path difference for  $n$ th dark fringe on the screen

$$\frac{xd}{D} = \left(n + \frac{1}{2}\right)\lambda$$

$$x_n = \frac{\left(n + \frac{1}{2}\right)\lambda D}{d}$$

For  $(n+1)$ th dark fringe

$$x_{n+1} = \frac{\left(n + \frac{3}{2}\right)\lambda D}{d}$$

Fringe width  $\beta = x_{n+1} - x_n$

$$= \frac{\lambda D}{d}$$

1/2

(c) The intensity at a point on the screen where waves meet with a phase difference ( $\phi$ ), is given by



$$I = 4I_0 \cos^2 \phi / 2$$

Phase difference ( $\phi$ ) when path difference is 'x'

$$\phi = \frac{2\pi}{\lambda} \cdot x$$

$\therefore$  for  $x = \lambda$ , we have

$$\phi = 2\pi$$

$$\therefore \text{Intensity } I = 4I_0 \cos^2 \pi = K$$

$$\therefore 4I_0 = K$$

$$\therefore I_0 = K/4$$

Phase difference, when path difference is  $\lambda/4$ , is

$$\phi' = \frac{2\pi}{\lambda} \cdot \lambda/4 = \pi/2$$

$$\therefore I' = 4I_0 \cos^2 \pi/4$$

$$= 2I_0$$

$$= 2 \frac{K}{4} = K/2$$

**OR**

(a) Sketch of the refracted wave front	1
(b) Verification of laws of refraction	2
(c) Estimation of speed and wavelength	1+1

(a)

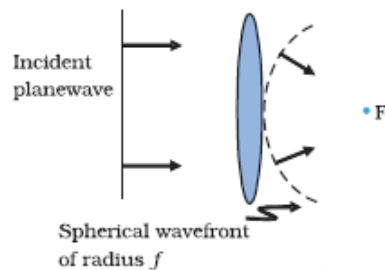

(b)

1/2

5

1

1/2

1/2

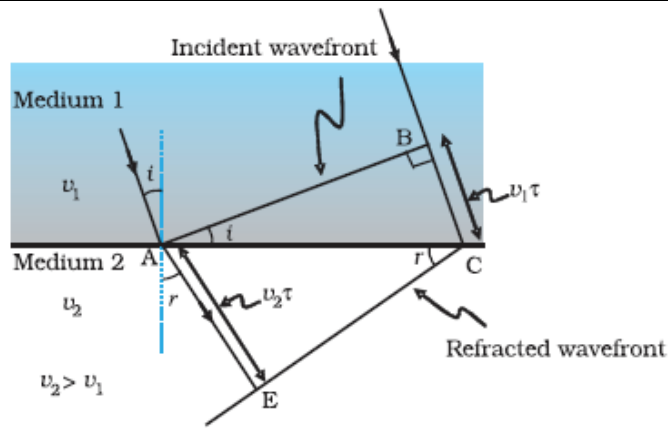

In right triangle ABC

$$\sin i = \frac{BC}{AC}$$

In  $\triangle AEC$

$$\sin r = \frac{AE}{AC}$$

$$\frac{\sin i}{\sin r} = \frac{BC}{AE} = \frac{v_1 \tau}{v_2 \tau} = \frac{v_1}{v_2} = \mu$$

(c) Speed of yellow light inside the glass slab

$$\begin{aligned} v &= \frac{c}{\mu} \\ &= \frac{3 \times 10^8}{1.5} \text{ m/s} \\ &= 2 \times 10^8 \text{ m/s} \end{aligned}$$

Wavelength of yellow light inside the glass slab

$$\begin{aligned} \lambda' &= \frac{\lambda}{\mu} \\ &= \frac{590}{1.5} \text{ nm} \\ &= 393.33 \text{ nm} \end{aligned}$$

1/2

1/2

1/2

1/2

1/2

1/2

5