

**2019  
PHYSICS**

Total marks : 70

Time : 3 hours

**General instructions :**

- i) *Approximately 15 minutes is allotted to read the question paper and revise the answers.*
- ii) *The question paper consists of 30 questions. All questions are compulsory.*
- iii) *Marks are indicated against each question.*
- iv) *Internal choice has been provided in some questions.*

**N.B:** *Check that all pages of the question paper is complete as indicated on the top left side.*

1. A charge  $q$  is enclosed by a Gaussian spherical surface of radius  $R$ . If the radius is doubled, then the outward electric flux will 1
  - (a) be doubled
  - (b) increase four times
  - (c) be reduced to half
  - (d) remain the same
  
2. If an ammeter is to be used in place of a voltmeter, then you must connect with the ammeter of a 1
  - (a) low resistance in parallel
  - (b) high resistance in parallel
  - (c) high resistance in series
  - (d) low resistance in series
  
3. A circuit has a resistance of  $12\Omega$  and an impedance of  $15\Omega$ . The power factor of the circuit will be 1
  - (a) 0.8
  - (b) 0.4
  - (c) 1.25
  - (d) 0.125
  
4. The stopping potential doubles when the frequency of the incident light changes from  $\nu$  to  $\frac{3}{2}\nu$ . The work function of the metal must be 1
  - (a)  $\frac{1}{2}h\nu$
  - (b)  $h\nu$
  - (c)  $2h\nu$
  - (d) none of these.
  
5. The mobile telephones operate typically in the range of 1
  - (a) 100 – 200 MHz
  - (b) 800 – 950 MHz
  - (c) 1000 – 2000 MHz
  - (d) 88 – 108 MHz.
  
6. Name any one application of electrical resonance phenomena. 1

7. What is the source of an electromagnetic wave? 1
8. State Huygen's principle of diffraction of light. 1
9. Two nuclei have mass numbers in the ratio 1:8. What is the ratio of their nuclear radii? 1
10. What is Global Positioning System? 1
11. State Coulomb's law of electrostatic. Show that the electrostatic forces between two static charges separated by a distance follow Newton's third law of motion. 2
12. a. Two charges of  $+5\text{nC}$  and  $-2\text{nC}$  are placed at points  $(5\text{cm}, 0,0)$  and  $(23\text{cm}, 0,0)$  in a region of space where there is no other external electric field. Calculate potential energy of this charge system. 2  
 Or  
 b. Three capacitors are connected as shown in the following figure. Calculate the resultant capacitance. If the combination is connected across a  $30\text{V}$  DC battery, find the total charge drawn by the arrangement.

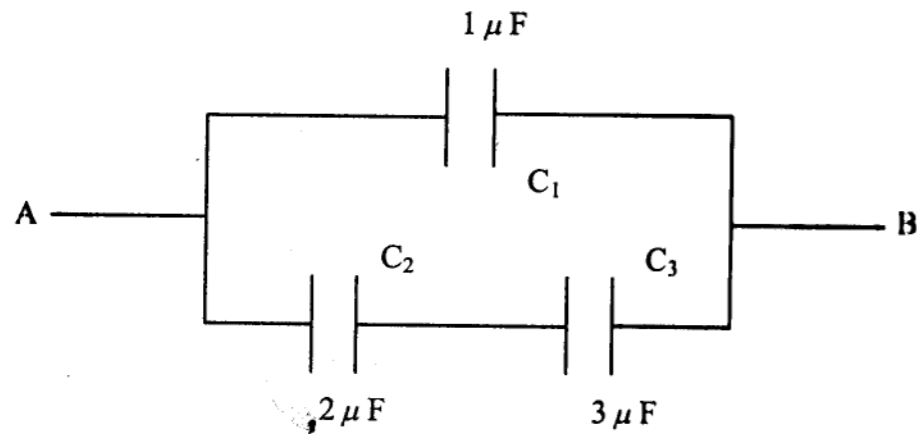

13. Derive an expression for the resistivity of a conductor in terms of number density of free electrons and relaxation time. 2
14. Deduce an expression for the magnetic dipole moment of an electron orbiting around the central nucleus. 2
15. a. What are electromagnetic waves? Write the equations for associated electric and magnetic fields clearly mentioning their directions. 2  
 Or  
 b. Write any four properties of electromagnetic waves.

16. a. Draw the graph showing the variation of current with voltage for a p-n junction diode, when the diode is (i) forward biased and (ii) reverse biased. 2

Or

- b. Identify the logic gates X and Y in the following figure. Write down the truth table for output Z for all possible inputs A and B. 2

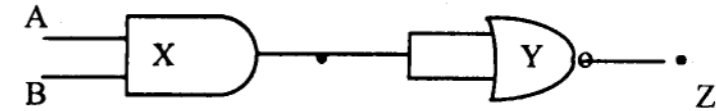

17. Prove that total electrostatic potential energy stored in a capacitor is  $\frac{1}{2}CV^2$ . Hence, derive an expression for the energy density of an electric field. 3
18. Draw a circuit diagram of a Wheatstone bridge. Using Kirchhoff's rules, obtain the balance condition for the network. 3
19. a. In the arrangement of cells and resistors shown in the figure, calculate the current in each resistor. 3

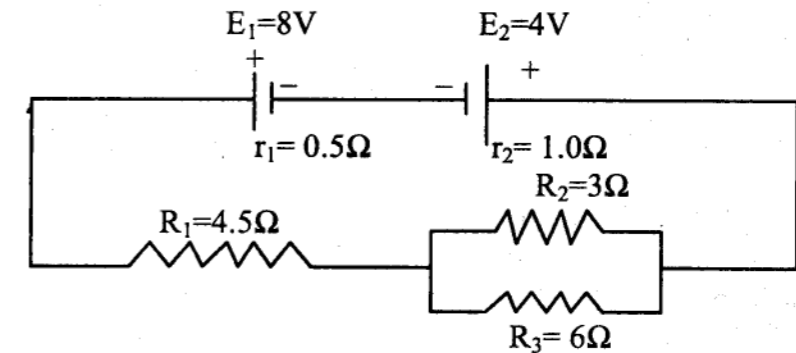

Or

- b. A heater coil is rated  $100\text{W}, 200\text{V}$ . It is cut into two identical parts. Both parts are connected together in parallel to the same source of  $200\text{V}$ . Calculate the energy liberated per second in the new combination. 3
20. A rectangular coil of  $500$  turns, each of area  $200\text{cm}^2$ , rotates in a uniform magnetic field of  $0.28\text{Wb m}^{-2}$ . The rotation axis of the coil is perpendicular to the field and frequency of rotation is  $50\text{cps}$ . Calculate the peak emf induced between the ends of the coil. If the coil has a resistance of  $24\ \Omega$ , what is the peak current flowing in the circuit? 3

21. a. A metallic rod of length  $l$  is rotated at constant angular speed  $\omega$  normal to a uniform magnetic field  $B$ . Derive an expression for the emf induced in the rod.  
**Or** 3  
 b. Define the term 'rms value of an AC'. Obtain a relation between the rms value and the peak value of AC.
22. A ray of light is incident on one face of a prism and emerges out from the other face. Draw a ray diagram and derive an expression for refractive index of the material of the prism. 3
23. In a Young's double slit interference experiment, the ratio of intensity at the maxima and minima in the interference pattern is  $\frac{25}{9}$ . What will be the ratio of amplitudes of light emitted by the two slits? 3
24. a. What is photo electric effect? State the laws of photo-electric emission.  
**Or** 3  
 b. Show that de-Broglie wavelength of electron when accelerated through a potential difference  $V$  is given by the relation -  

$$\lambda = \frac{12.27}{\sqrt{V}} \text{ \AA}, \text{ where } V \text{ is in volt.}$$
25. Calculate the wavelength of first spectral line of Balmer series for hydrogen. Given that Rydberg constant,  $R = 1.097 \times 10^7 \text{ m}^{-1}$  3
26. a. Derive an expression for the total energy of an electron in any orbit of a hydrogen atom in accordance with Bohr's atomic model.  
**Or** 3  
 b. State the radio-active decay law. Deduce the relation  $N = N_0 e^{-\lambda t}$ , where the symbols have their usual meanings
27. Explain any two factors which justify the need for modulating a signal. 3
28. a. State Biot-Savart law. Use this law to obtain the expression for the magnetic field on the axis of a circular current loop.  
**Or** 5  
 b. With the help of a diagram, explain the principle and working of a cyclotron. Show that cyclotron frequency does not depend on the speed of the particles.

29. a. Derive the lens maker's formula for a thin double convex lens. Why is it called so? .  
**Or** 5  
 b. Draw a neat ray diagram to show the image formation in a compound microscope. Define its magnifying power and derive an expression for it, when the final image is at near point of eye.
30. a. State the principle of working of p-n diode as a rectifier. With the help of circuit diagram, explain the use of p-n junction diodes as a full wave rectifier. Draw input and output wave forms.  
**Or** 5  
 b. Explain with the help of a labelled circuit diagram, how an n-p-n transistor can be used as an amplifier in common emitter configuration. Also, explain how input and output voltages are out of phase by  $180^\circ$  for a common emitter transistor amplifier.

\*\*\*\*\*